



Fire Detection in a Battery Warehouse

Fujian, China

Project Overview

Amperex Technology is a market leader in the design and manufacture of rechargeable lithium ion/polymer battery cells and related battery packs and systems. The company's battery warehouse in Fujian has the capacity to store 7,000 batteries and packs.

In the manufacturing of storage cells, Li-Ion presents a potential for overheating, requiring the manufacturer and end-user to exercise the utmost care. The industry for storage cells is associated with diverse chemicals within the storage cells, which present a risk where chemical leakage may occur over time. For example, lead acid cells have the potential to release hydrogen gas. While the gas is not toxic, at high concentration levels it is a highly explosive gas, which creates an explosive environment. To mitigate the risk of overheating or a fire, Amperex selected four AP Sensing Linear Heat Detection (LHD) devices to protect the warehouse.

Solution

Typically, the temperature inside the battery warehouse is regulated by air-conditioning, since Fujian's summers are hot and humid. However, with each battery activated, the temperature will rise. If the battery is faulty, it may result into a spontaneous combustion with severe consequences for assets and human lives.

AP Sensing's reliable LHD system, based on Distributed Temperature Sensing (DTS) technology, detects this abnormal heat development. Each of the four LHD devices each cover one km and have four channels utilizing a passive sensor cable. The units are installed in a rack in a remote control room.

The passive sensor cable has many advantages, because it is immune to dirt, dust, humidity, corrosive materials and electromagnetic interference (EMI). Due to the volatile nature of the chemical involved in



Background

- Storage of battery cells in a potentially explosive area
- World market leader looking for a reliable and flexible fire detection solution



Solution & Benefits

- Four Linear Heat Detection (LHD) devices
- ATEX and IECEx certified solution for highly explosive areas
- Individually-defined alarm zones and criteria
- 24/7 real-time monitoring data and trend analysis
- SmartVision for an intuitive overview

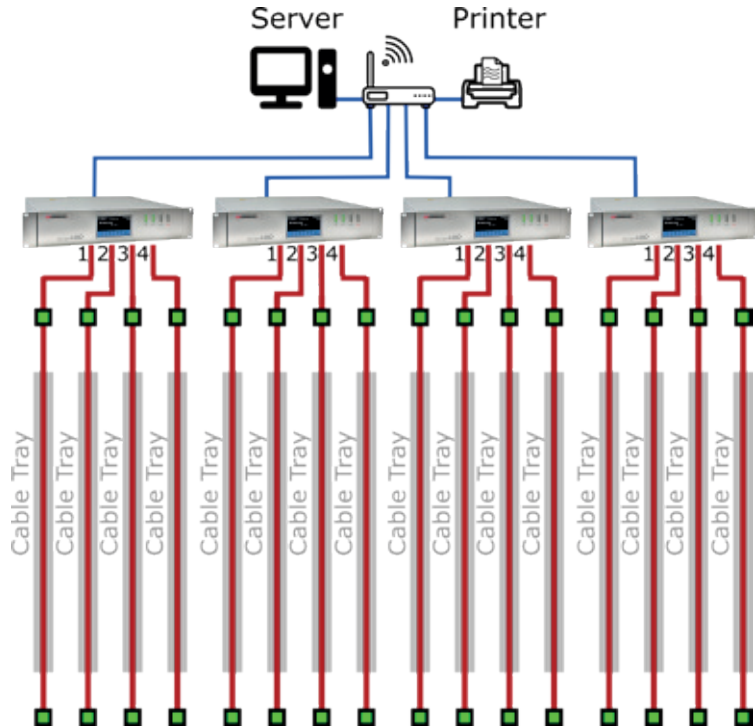

System configuration and rack installation

manufacturing, storage and in-use of batteries, an explosive atmosphere could develop. Our system complies to European ATEX and International IECEx directives without requiring special housing - simplifying installation and maintenance.

Installation

The battery warehouse has seven layers of shelves, with each layer separated by a fireproof panel. The cable was installed around the perimeters of these fireproof panels as shown below.

Every loop of the LHD solution can be divided into 256 alarm zones, and each zone can be defined with individual alarm criteria. The four LHD units present concise temperature information within the entire warehouse, enabling the protection of two storage shelf locations in one alarm zone. This results in more than 3,500 alarm zones for this installation, enabling the operator to precisely identify and locate abnormal heat build-up anywhere within the warehouse.

Each LHD device is equipped with a Modbus TCP slave module and alarm configurations for each zone. The average and maximum temperatures for each zone are relayed to the SCADA system via Modbus TCP protocol.

In addition to SCADA, our stand-alone visualization software, SmartVision, provides the operator with an overview of the warehouse layout on screen, identifying zones and real-time temperatures as well as trends of storage temperatures. In case abnormal behavior occurs, an alarm and the hotspot location are shown on the screen.

The system passed the Final Acceptance Test (FAT) without any issues, and has been functioning properly since installation. A valuable infrastructure remains protected.



Optical fiber cable installation in the warehouse